



目录	页面	Contents	Page
T系列伞齿轮转向器		T series Bevel Gear Redirector	
产品外形	175-175	Products Figure	175-175
型号标记	176-176	Designation	176-176
安装位置	177-180	Mounting Position	177-180
技术参数	181-184	Technical Data	181-184
安装尺寸	185-189	Mounting Dimensions	185-189



产品外形

Products Figure

L-LR..

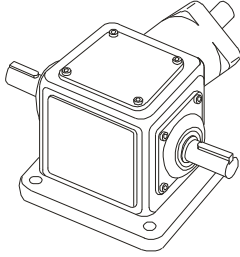

L-L..

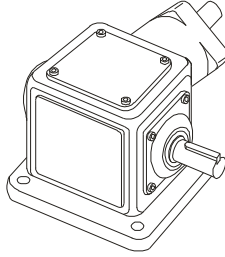

L-R..

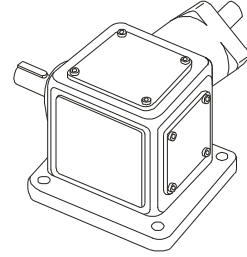

L-UD..

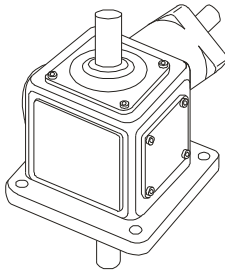

L-U..

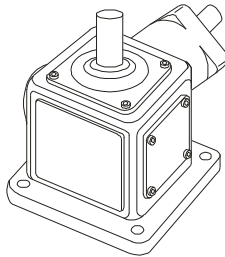

L-D..

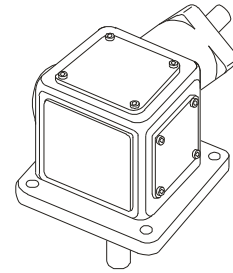

U-LR..

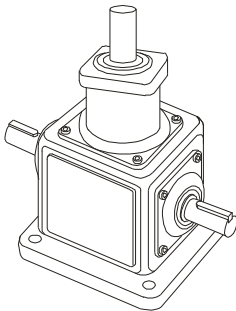

U-L..

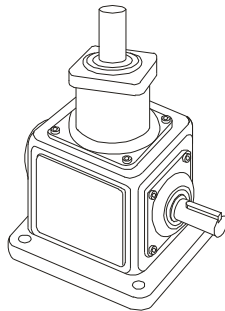

U-R..

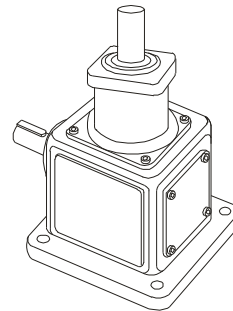

D-LR..

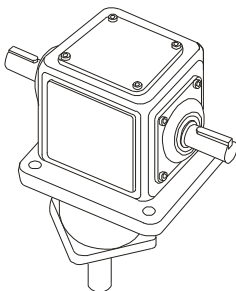

D-L..

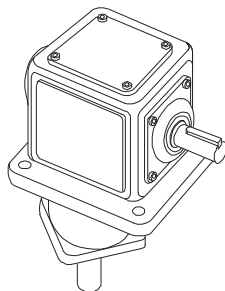

D-R..

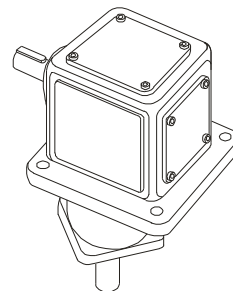



型号标记

Designation

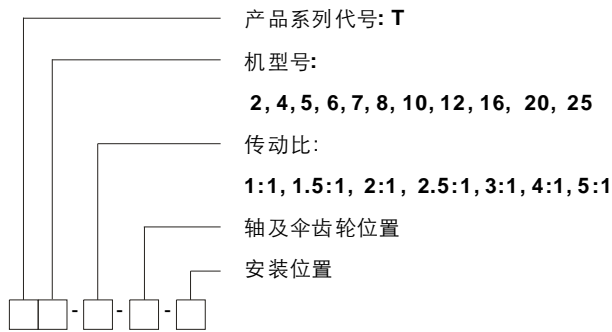

Products series code
gear unit size:
2, 4, 5, 6, 7, 8, 10, 12, 16, 20, 25
transmission ratio
1:1, 1.5:1, 2:1, 2.5:1, 3:1, 4:1, 5:1
shaft and bevel gear position
mounting position

标记示例

- A T2-1:1-L-LR-M1**
机型号T2, 传动比1:1, 水平输入 (L), 轴及伞齿轮位置LR, 安装位置M1
- B T4-2:1-L-U-M2**
机型号T4, 传动比2:1, 水平输入 (L), 轴及伞齿轮位置U, 安装位置M2
- C T6-2.5:1-U-R-O-M5**
机型号T6, 传动比2.5:1, 顶端输入 (U), 轴及伞齿轮位置R-O, 安装位置M5
- D T8-3:1-D-L-M3**
机型号T8, 传动比3:1, 底端输入 (D), 轴及伞齿轮位置L, 安装位置M3

Sign Example

- A T2-1:1-L-LR-M1**
gear unit size T2, transmission ratio 1:1, horizontal input(L), shaft and bevel gear position LR, mounting position M1
- B T4-2:1-L-U-M2**
gear unit size T4, transmission ratio 2:1, horizontal input(L), shaft and bevel gear position U, mounting position M2
- C T6-2.5:1-U-R-O-M5**
gear unit size T6, transmission ratio 2.5:1, upperside input (U), shaft and bevel gear position R-O, mounting position M5
- D T8-3:1-D-L-M3**
gear unit size T8, transmission ratio 3:1, underside input(D), shaft and bevel gear position L, mounting position M3

转向器重量(kg)

Redirector weight(kg)

机型号 /Size	T2	T4	T6	T7	T8	T10	T12	T16	T20	T25
重量 /Weight	2	10	21	32	49	78	124	188	297	488



安装位置

Mounting Position

L-L..., L-R..., L-LR.. 安装位置

L-L..., L-R..., L-LR.. Redirector Mounting Position

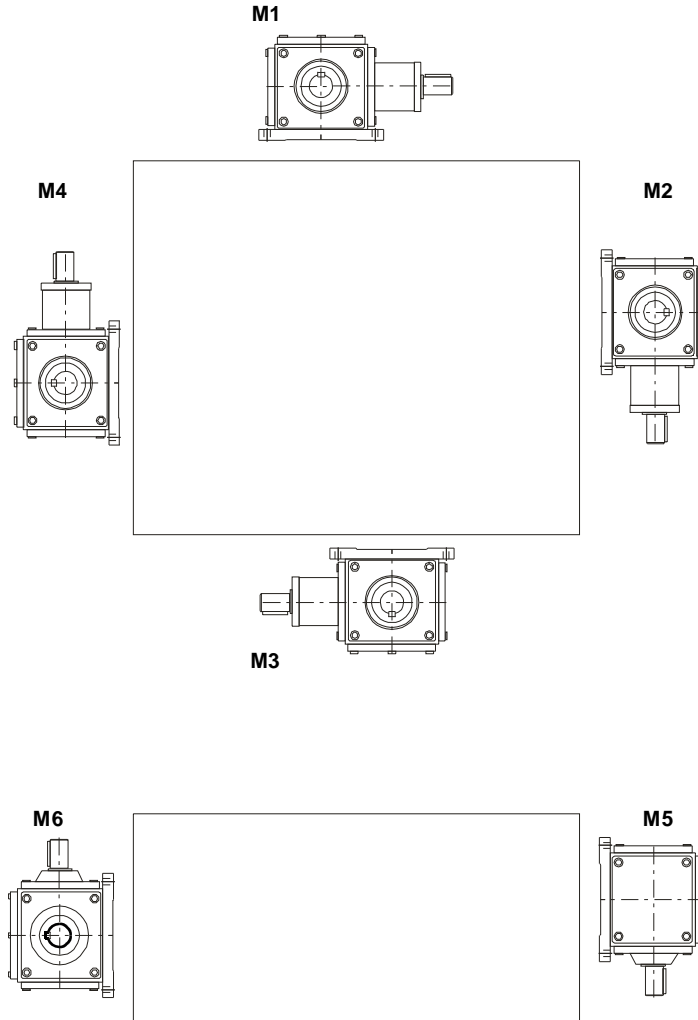

轴及齿轮配置

Bevel gear and shaft position

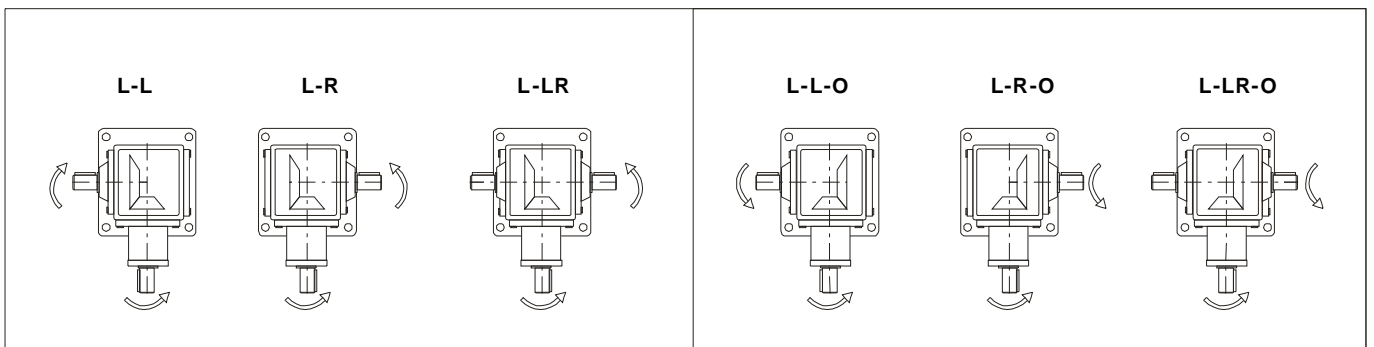



安装位置

Mounting Position

D-L..., D-R..., D-LR..减速机安装位置

D-L..., D-R..., D-LR.. Gear Unit Mounting Position

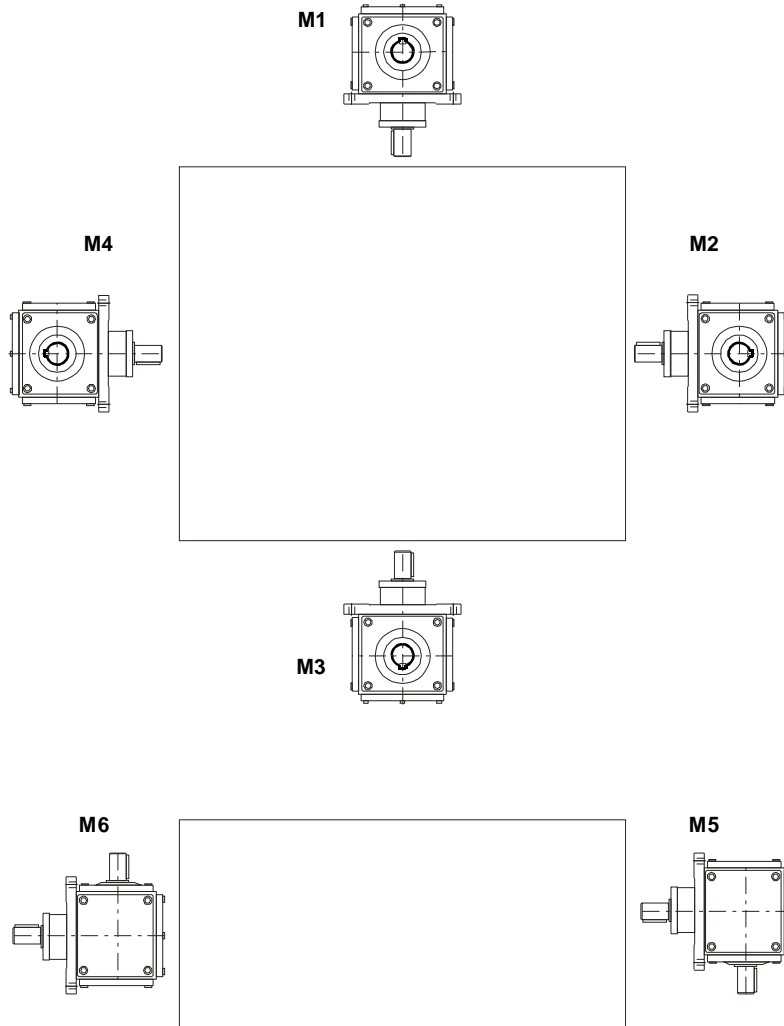

轴及齿轮配置

Bevel gear and shaft position

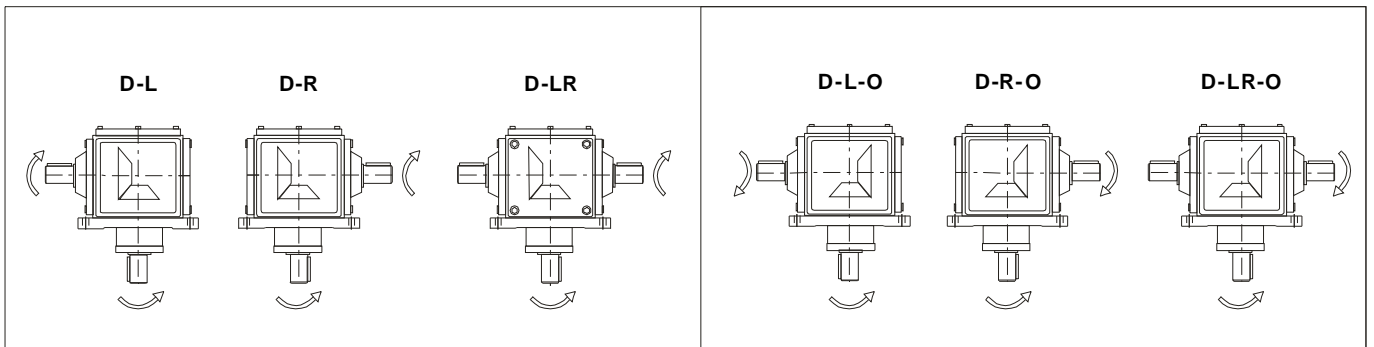



安装位置

Mounting Position

U-L..., U-R..., U-LR..转向器安装位置

U-L..., U-R..., U-LR.. Gear Unit Mounting Position

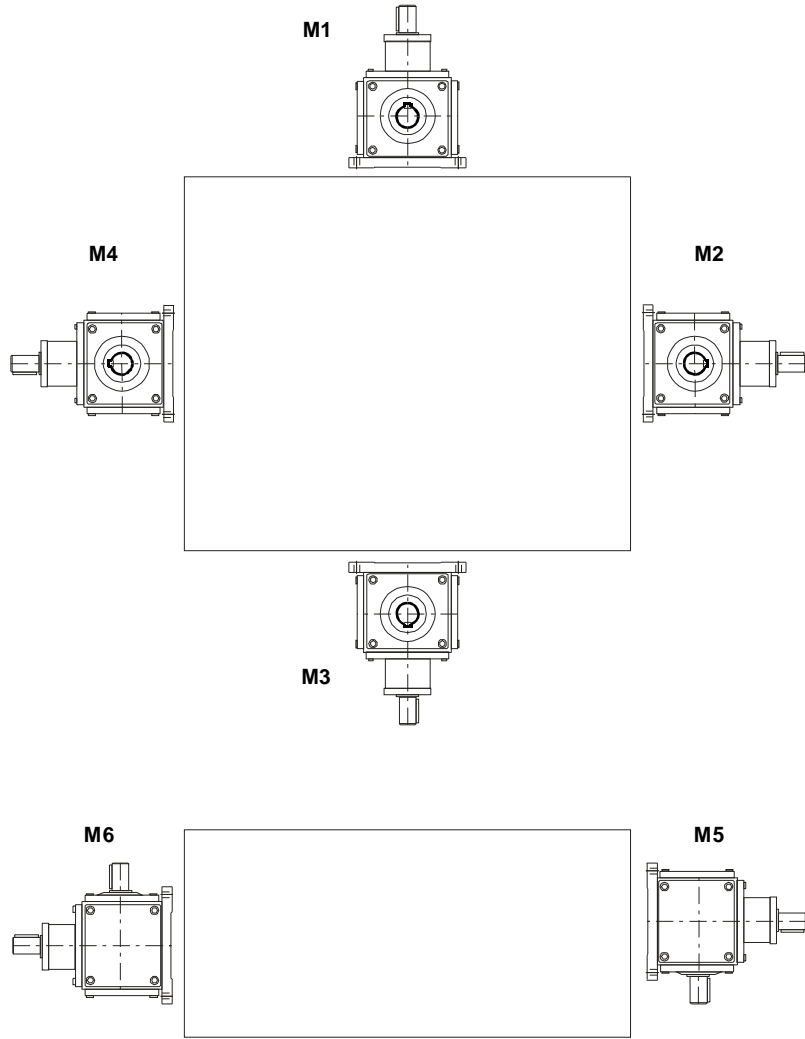

轴及齿轮配置

Bevel gear and shaft position

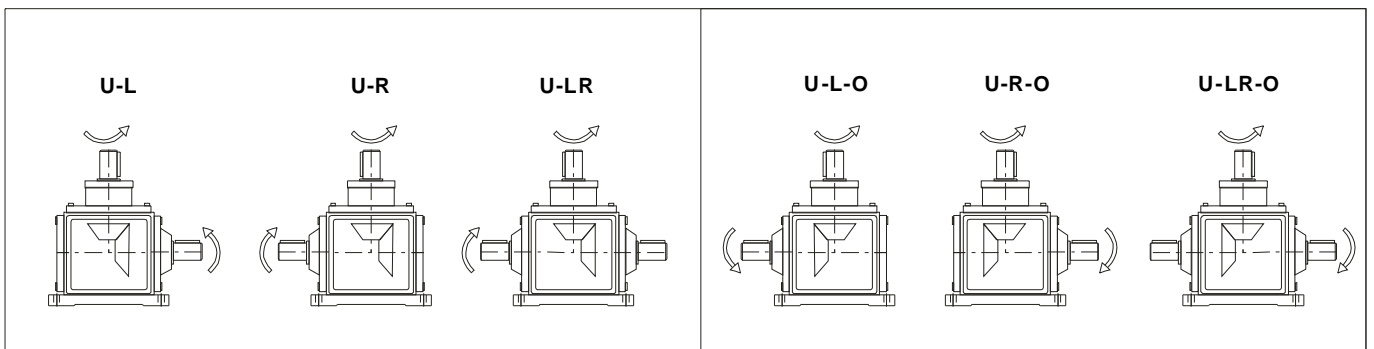



安装位置

Mounting Position

L-U...,L-D...,L-UD..转向器安装位置

L-U...,L-D...,L-UD.. Redirector Mounting Position

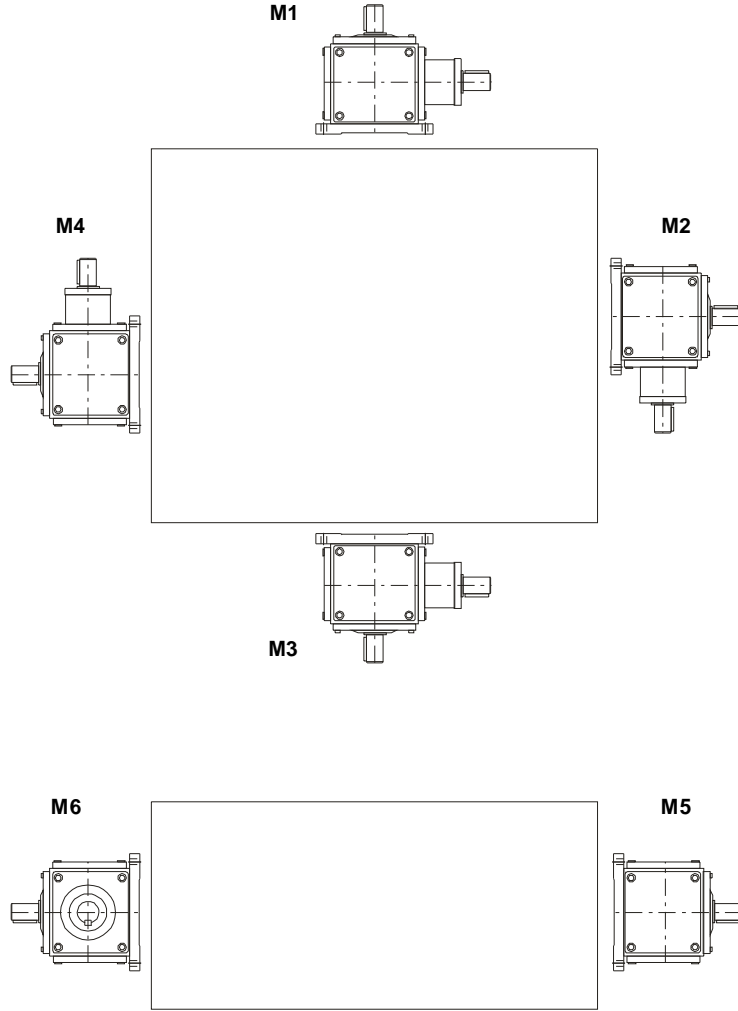

轴及齿轮配置

Bevel gear and shaft position

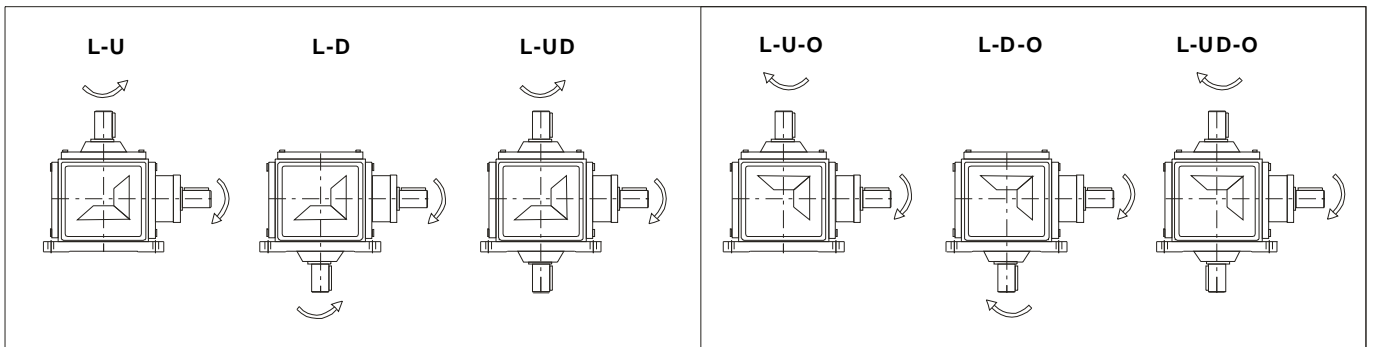



技术参数

Technical Data

符号意义

Key to Symbols



机型号/SIZE		T2				T4				T6				T7			
I	n1 rpm	Mn2 N.m	Pn1 KW	Fr1 N	Fr2 N	Mn2 N.m	Pn1 KW	Fr1 N	Fr2 N	Mn2 N.m	Pn1 KW	Fr1 N	Fr2 N	Mn2 N.m	Pn1 KW	Fr1 N	Fr2 N
	1450	11.6	1.79	265	216	31.9	4.94	833	951	96	14.9	1911	2450	142	22.0	2450	3136
	1150	11.7	1.43	323	235	34.1	4.19	882	1029	103	12.7	2058	2597	150	18.4	2744	3234
	870	12.1	1.12	402	255	37.2	3.46	960	1127	113	10.5	2205	2842	164	15.2	2989	3381
	580	12.1	0.747	549	314	39.5	2.45	1078	1323	119	7.35	2499	3185	184	11.4	3381	3822
1:1	400	12.3	0.524	637	353	40.2	1.72	1372	1715	122	5.20	3185	3528	195	8.34	4018	4900
	300	12.3	0.396	696	392	40.5	1.30	1519	1960	123	3.93	3430	3528	198	6.35	4410	5537
	200	12.4	0.226	784	441	41.2	0.88	1911	1960	124	2.66	3430	3528	201	4.30	5096	6272
	100	12.7	0.136	980	588	41.9	0.448	1911	1960	127	1.360	3430	3528	206	2.20	5096	6272
	10	13.0	0.014	980	588	43.0	0.046	1911	1960	132	0.141	3430	3528	214	0.228	5096	6272

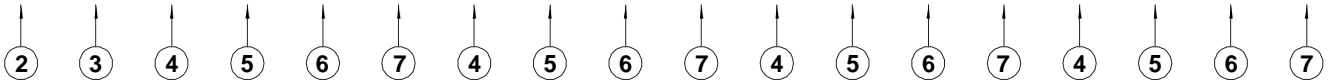

1 机型号

2 传动比

3 输入转速

4 额定输出转矩

5 额定输入功率

6 输入轴中点最大径向力

7 输出轴中点最大径向力

1 redirector size

2 transmission ratio

3 input speed

4 rated output torque

5 rated input power

6 max radial force on the middle of input shaft

7 max radial force on the middle of output shaft



技术参数

Technical Data

机型号/SIZE		T2				T4				T6				T7			
I	n1 rpm	Mn2 N.m	Pn1 KW	Fr1 N	Fr2 N	Mn2 N.m	Pn1 KW	Fr1 N	Fr2 N	Mn2 N.m	Pn1 KW	Fr1 N	Fr2 N	Mn2 N.m	Pn1 KW	Fr1 N	Fr2 N
1:1	1450	11.6	1.79	265	216	31.9	4.94	833	951	96	14.9	1911	2450	142	22.0	2450	3136
	1150	11.7	1.43	323	235	34.1	4.19	882	1029	103	12.7	2058	2597	150	18.4	2744	3234
	870	12.1	1.12	402	255	37.2	3.46	960	1127	113	10.5	2205	2842	164	15.2	2989	3381
	580	12.1	0.747	549	314	39.5	2.45	1078	1323	119	7.35	2499	3185	184	11.4	3381	3822
	400	12.3	0.524	637	353	40.2	1.72	1372	1715	122	5.20	3185	3528	195	8.34	4018	4900
	300	12.3	0.396	696	392	40.5	1.30	1519	1960	123	3.93	3430	3528	198	6.35	4410	5537
	200	12.4	0.226	784	441	41.2	0.88	1911	1960	124	2.66	3430	3528	201	4.30	5096	6272
	100	12.7	0.136	980	588	41.9	0.448	1911	1960	127	1.360	3430	3528	206	2.20	5096	6272
	10	13.0	0.014	980	588	43.0	0.046	1911	1960	132	0.141	3430	3528	214	0.228	5096	6272
	1.5:1	1450									117	12.1	2548	2842	142	22.0	2450
1150										122	9.96	3038	3087	150	18.4	2744	3234
870										123	7.66	3430	3332	164	15.2	2989	3381
580										126	5.23	3430	3528	184	11.4	3381	3822
400										128	3.66	3430	3528	195	8.34	4018	4900
300										129	2.77	3430	3528	198	6.35	4410	5537
200										131	1.87	3430	3528	201	4.30	5096	6272
100										134	0.957	3430	3528	206	2.20	5096	6272
10										139	0.099	3430	3528	214	0.228	5096	6272
2:1		1450	12.1	0.94	265	172	42.8	3.32	1078	1960	102	7.90	2548	2842	137	10.6	3430
	1150	12.0	0.74	323	211	43.4	2.67	1078	1960	104	6.39	3038	3087	139	8.55	4067	6076
	870	12.0	0.56	402	230	43.8	2.04	1078	1960	105	4.88	3430	3332	141	6.56	4753	6174
	580	11.9	0.37	549	283	44.4	1.38	1078	1960	108	3.34	3430	3528	144	4.47	5096	6272
	400	12.2	0.26	637	318	45.1	0.96	1078	1960	109	2.33	3430	3528	146	3.12	5096	6272
	300	11.9	0.19	696	353	45.5	0.73	1078	1960	110	1.76	3430	3528	148	2.37	5096	6272
	200	12.2	0.13	784	397	46.1	0.49	1078	1960	111	1.18	3430	3528	149	1.59	5096	6272
	100	11.2	0.06	980	530	46.6	0.25	1078	1960	114	0.608	3430	3528	152	0.812	5096	6272
	10	28.1	0.015	980	530	48.5	0.026	1078	1960	116	0.062	3430	3528	157	0.084	5096	6272
	2.5:1	1450									96.2	5.97	2548	2842	113	6.99	3430
1150										97.2	4.78	3038	3087	115	5.64	4067	6076
870										99.0	3.68	3430	3332	116	4.30	4753	6174
580										100.0	2.48	3430	3528	118	2.92	5096	6272
400										100.9	1.73	3430	3528	120	2.05	5096	6272
300										102.9	1.32	3430	3528	121	1.55	5096	6272
200										103.9	0.888	3430	3528	123	1.05	5096	6272
100										104.9	0.448	3430	3528	123	0.528	5096	6272
10										107.8	0.046	3430	3528	126	0.054	5096	6272
3:1		1450									93.6	4.84	2548	2842	105	5.42	3430
	1150									94.8	3.88	3038	3087	106	4.34	4067	6076
	870									95.9	2.97	3430	3332	108	3.34	4753	6174
	580									97.6	2.02	3430	3528	109	2.25	5096	6272
	400									99.0	1.41	3430	3528	111	1.58	5096	6272
	300									100	1.07	3430	3528	111	1.18	5096	6272
	200									100	0.712	3430	3528	113	0.803	5096	6272
	100									102	0.363	3430	3528	115	0.409	5096	6272
	10									104	0.037	3430	3528	118	0.042	5096	6272



技术参数

Technical Data

机型号/SIZE		T8				T10				T12			
I	n1 rpm	Mn2 N.m	Pn1 KW	Fr1 N	Fr2 N	Mn2 N.m	Pn1 KW	Fr1 N	Fr2 N	Mn2 N.m	Pn1 KW	Fr1 N	Fr2 N
1:1	1450	294	45.6	3234	3381	421	65.3	4165	4508	619	96.0	5096	5586
	1150	305	37.5	3479	3626	453	55.7	4459	4851	665	81.1	5488	6076
	870	312	29.0	3773	3969	479	44.6	4851	5292	726	67.5	5880	6566
	580	319	19.8	4263	4459	493	30.6	5488	5880	802	49.7	6713	7301
	400	326	14.0	4851	5978	504	21.5	6272	7056	821	35.1	7742	8134
	300	331	10.6	5243	6958	513	16.4	6713	7987	835	26.8	8232	9065
	200	338	7.23	7889	8820	521	11.1	8575	9604	852	18.2	9261	10290
	100	346	3.70	8428	8820	535	5.72	9996	11760	875	9.36	11368	12593
	10	361	0.386	8428	8820	561	0.599	9996	11760	919	0.98	11858	14504
1.5:1	1450	185	19.1	7987	5194	374	38.7	5194	9212	564	58.3	5978	10486
	1150	188	15.4	8820	6174	380	31.2	6174	10486	601	49.2	7252	12152
	870	191	11.8	8820	7448	389	24.1	7448	11760	656	40.7	8869	14504
	580	197	8.14	8820	9555	396	16.4	9555	11760	699	28.9	11466	14504
	400	200	5.70	8820	9996	406	11.6	9996	11760	711	20.3	11858	14504
	300	203	4.34	8820	9996	411	8.78	9996	11760	724	15.5	11858	14504
	200	204	2.91	8820	9996	417	5.95	9996	11760	736	10.5	11858	14504
	100	210	1.49	8820	9996	426	3.04	9996	11760	754	5.37	11858	14504
	10	218	0.155	8820	9996	443	0.316	9996	11760	785	0.56	11858	14504
2:1	1450	180	14.0	7987	5194	305	23.6	5194	9212	516	40.0	5978	10486
	1150	183	11.3	8820	6174	309	19.0	6174	10486	516	31.7	7252	12152
	870	187	8.70	8820	7448	315	14.6	7448	11760	516	24.0	8869	14504
	580	191	5.92	8820	9555	322	10.0	9555	11760	524	16.3	11466	14504
	400	194	4.15	8820	9996	328	7.02	9996	11760	538	11.5	11858	14504
	300	196	3.14	8820	9996	332	5.33	9996	11760	543	8.71	11858	14504
	200	198	2.12	8820	9996	338	3.61	9996	11760	551	5.89	11858	14504
	100	202	1.08	8820	9996	344	1.84	9996	11760	563	3.01	11858	14504
	10	209	0.112	8820	9996	357	0.191	9996	11760	586	0.313	11858	14504
2.5:1	1450	184	11.4	7987	5194	293	18.2	5194	9212	507	31.4	5978	10486
	1150	185	9.11	8820	6174	298	14.7	6174	10486	514	25.3	7252	12152
	870	188	7.00	8820	7448	302	11.2	7448	11760	523	19.5	8869	14504
	580	192	4.76	8820	9555	310	7.68	9555	11760	535	13.3	11466	14504
	400	195	3.34	8820	9996	315	5.38	9996	11760	545	9.32	11858	14504
	300	197	2.53	8820	9996	317	4.06	9996	11760	552	7.08	11858	14504
	200	200	1.71	8820	9996	321	2.75	9996	11760	560	4.79	11858	14504
	100	203	0.867	8820	9996	326	1.40	9996	11760	568	2.43	11858	14504
	10	208	0.089	8820	9996	336	0.144	9996	11760	588	0.251	11858	14504
3:1	1450	159	8.20	7987	5194	270	14.0	5194	9212	458	23.6	5978	10486
	1150	160	6.55	8820	6174	275	11.3	6174	10486	464	19.0	7252	12152
	870	163	5.04	8820	7448	279	8.66	7448	11760	469	14.6	8869	14504
	580	166	3.42	8820	9555	285	5.89	9555	11760	480	9.92	11466	14504
	400	168	2.39	8820	9996	288	4.11	9996	11760	490	6.98	11858	14504
	300	169	1.80	8820	9996	291	3.11	9996	11760	495	5.29	11858	14504
	200	171	1.22	8820	9996	294	2.10	9996	11760	501	3.57	11858	14504
	100	173	0.618	8820	9996	300	1.07	9996	11760	510	1.82	11858	14504
	10	179	0.064	8820	9996	308	0.11	9996	11760	527	0.188	11858	14504



技术参数

Technical Data

机型号/SIZE		T16				T20				T25			
I	n1 rpm	Mn2 N.m	Pn1 KW	Fr1 N	Fr2 N	Mn2 N.m	Pn1 KW	Fr1 N	Fr2 N	Mn2 N.m	Pn1 KW	Fr1 N	Fr2 N
1:1	1450	1019	163	10633	10976								
	1150	1098	139	11368	11760	1842	234	15386	15608				
	870	1186	114	12446	12740	2009	193	16660	17150	3489	335	24794	25480
	580	1343	85.9	14014	14504	2274	145	18816	19404	3940	252	28028	28910
	400	1499	66.1	15680	16170	2538	112	21070	21756	4410	195	31360	32340
	300	1637	54.1	17150	17640	2744	90.8	23422	24108	4792	159	34300	35280
	200	1784	39.3	19600	19894	3126	69.0	25970	26754	5390	119	38612	39788
	100	1842	20.3	22540	22540	3205	35.3	28420	32928	5439	60.0	39200	49000
	10	1940	2.14	22540	22540	3205	3.53	28420	33320	5713	6.30	39200	49000
2:1	1450	921	73.7	5978	12152	1578	126	7693	14602				
	1150	938	59.5	6419	13083	1607	102	8771	17934	3146	199	12985	24647
	870	958	46.0	6958	14210	1646	79.0	9506	19453	3224	155	13573	29400
	580	980	31.3	7840	16072	1695	54.2	10780	22001	3332	107	15680	33222
	400	1000	22.0	8820	17934	1725	38.0	12005	24598	3420	75.4	17542	37142
	300	1009	16.7	9604	19600	1574	29.0	13132	27342	3479	57.5	19159	40474
	200	1029	11.3	10829	22148	1784	19.7	14798	30282	3557	39.2	21658	45766
	100	1058	5.84	13328	22540	1833	10.1	18228	33320	3646	20.1	26656	49000
	10	1098	0.605	22540	22540	1921	1.06	28420	33320	3822	2.11	39200	49000
3:1	1450	904	48.2	5978	12152	1529	82.3	7693	14602	2935	158	10300	19550
	1150	920	38.9	6419	13083	1561	66.6	8771	17934	3045	130	12985	24647
	870	940	30.1	6958	14210	1598	51.6	9506	19453	3135	101	13573	29400
	580	960	20.4	7840	16072	1644	35.4	10780	22001	3246	69.9	15680	33222
	400	978	14.4	8820	17934	1672	24.8	12005	24598	3317	49.3	17542	37142
	300	990	10.9	9604	19600	1701	18.9	13132	27342	3372	37.6	19159	40474
	200	1005	7.38	10829	22148	1733	12.9	14798	30282	3449	25.6	21658	45766
	100	1038	3.82	13328	22540	1777	6.60	18228	33320	3537	13.1	26656	49000
	10	1076	0.40	22540	22540	1865	0.69	28420	33320	3713	1.4	39200	49000



安装尺寸

Mounting Dimensions

L-L(R)..

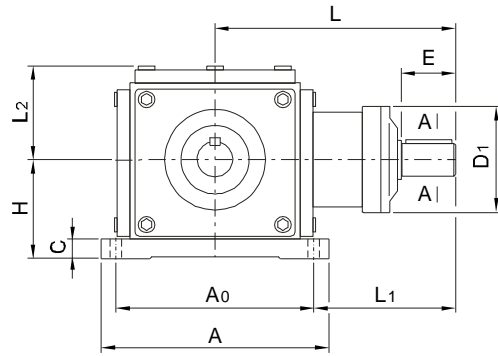
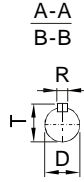
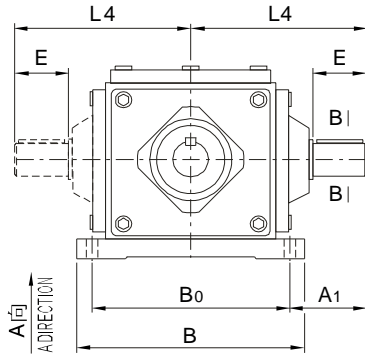

A向
ADIRECTION **T2-T16**

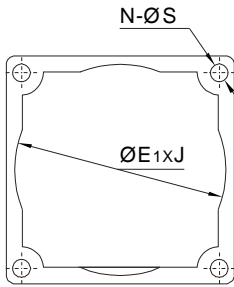

A向
ADIRECTION **T20-T25**

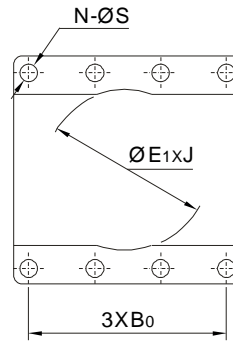

	A1	A	A0	B	B0	C	D1	D(h7)	E	E1	J	H	L	L1	L2	L4	N	R	S	T
T2	48	100	84	100	84	10	58	15	33	94	3	52	124	82	52	90	4	5	9	17
T4	53.5	155	125	155	125	17	76	19	38	155	5	76	180	117.5	76	116	4	6	10.5	21.5
T6	81	190	152	190	152	17	115	25	50	190	5	90	222	146	87	157	4	8	14	28
T7	88	210	174	210	174	20	125	32	62	220	5	100	265	178	99	175	4	10	14	35
T8	110.5	235	195	235	195	23	159	40	75	250	5	115	308	210.5	114.5	208	4	12	14	43
T10	120	285	240	285	240	25	155	45	90	305	5	140	360	240	133	265	4	14	16	48.5
T12	130	340	290	340	290	32	168	50	100	370	5	175	415	270	160	275	4	14	21	53.5
T16	150	390	330	390	330	40	193	60	105	420	7	200	455	290	186	315	4	18	25	64
T20	195	490	430	410	110	32	220	72	105	360	10	245	545	330	217	360	8	20	21	76.5
T25	235	580	520	480	130	35	270	85	130	430	10	290	660	400	255	430	8	22	24	90



安装尺寸

Mounting Dimensions

L-U(D)..

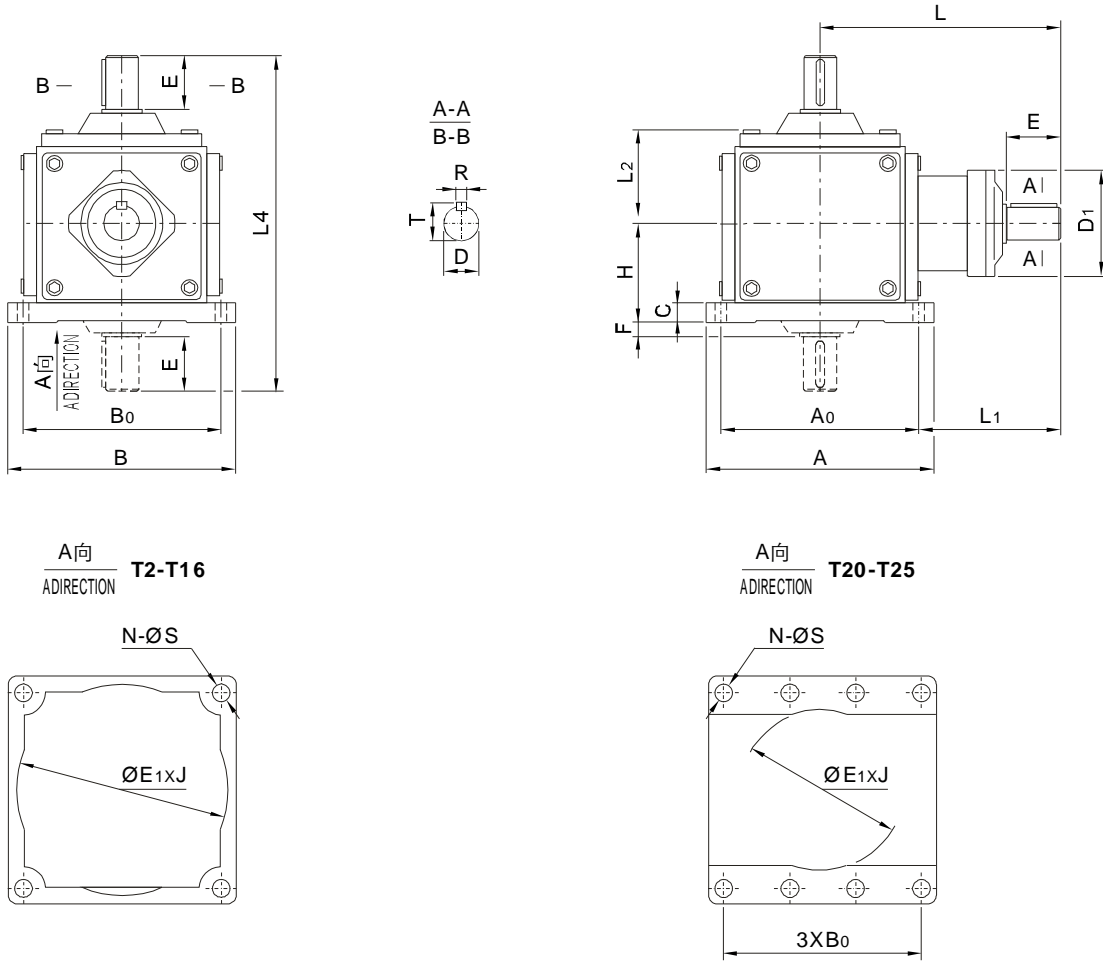

	A	A ₀	B	B ₀	C	D ₁	D(h7)	E	E ₁	F	J	H	L	L ₁	L ₂	L ₄	N	R	S	T
T2	100	84	100	84	10	58	15	33	94	5	3	52	124	82	52	180	4	5	9	17
T4	155	125	155	125	17	76	19	38	155	2	5	76	180	117.5	76	232	4	6	10.5	21.5
T6	190	152	190	152	17	115	25	50	190	17	5	90	222	146	87	314	4	8	14	28
T7	210	174	210	174	20	125	32	62	220	13	5	100	265	178	99	350	4	10	14	35
T8	235	195	235	195	23	159	40	75	250	18	5	115	308	210.5	114.5	416	4	12	14	43
T10	285	240	285	240	25	155	45	90	305	10	5	140	360	240	133	530	4	14	16	48.5
T12	340	290	340	290	32	168	50	100	370	0	5	175	415	270	160	550	4	14	21	53.5
T16	390	330	390	330	40	193	60	105	420	10	7	200	455	290	186	630	4	18	25	64
T20	490	430	410	110	32	220	72	105	360	10	10	245	545	330	217	720	8	20	21	76.5
T25	580	520	480	130	35	270	85	130	430	10	10	290	660	400	255	860	8	22	24	90



安装尺寸

Mounting Dimensions

U-L(R)..

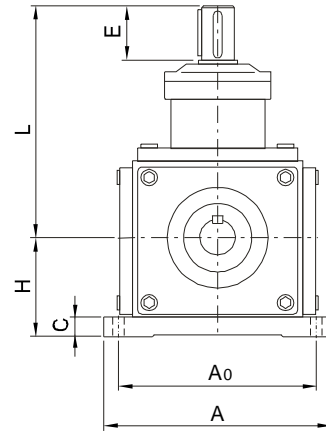
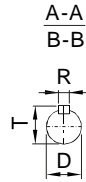
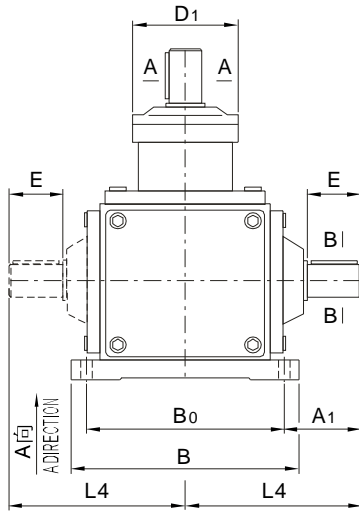

A向
ADIRECTION **T2-T16**

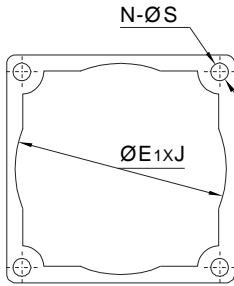

A向
ADIRECTION **T20-T25**

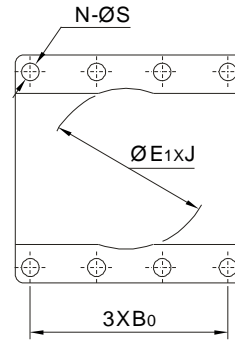

	A1	A	A0	B	B0	C	D1	D(h7)	E	E1	J	H	L	L4	N	R	S	T
T2	48	100	84	100	84	10	58	15	33	94	3	52	124	90	4	5	9	17
T4	53.5	155	125	155	125	17	76	19	38	155	5	76	180	116	4	6	10.5	21.5
T6	81	190	152	190	152	17	115	25	50	190	5	90	222	157	4	8	14	28
T7	88	210	174	210	174	20	125	32	62	220	5	100	265	175	4	10	14	35
T8	110.5	235	195	235	195	23	159	40	75	250	5	115	308	208	4	12	14	43
T10	120	285	240	285	240	25	155	45	90	305	5	140	360	265	4	14	16	48.5
T12	130	340	290	340	290	32	168	50	100	370	5	175	415	275	4	14	21	53.5
T16	150	390	330	390	330	40	193	60	105	420	7	200	455	315	4	18	25	64
T20	195	490	430	410	110	32	220	72	105	360	10	245	545	360	8	20	21	76.5
T25	235	580	520	480	130	35	270	85	130	430	10	290	660	430	8	22	24	90



安装尺寸

Mounting Dimensions

D-L(R)..

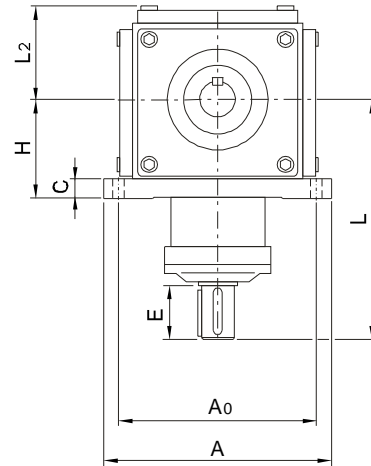
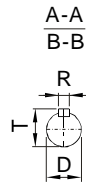
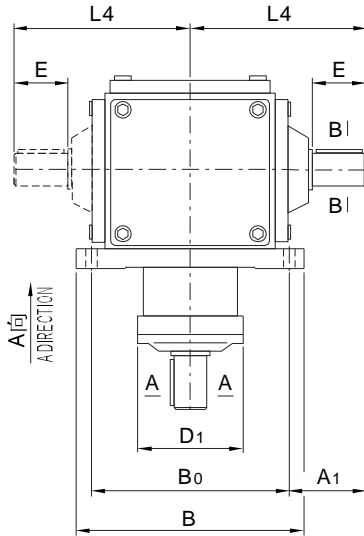

A向
ADIRECTION **T2-T16**

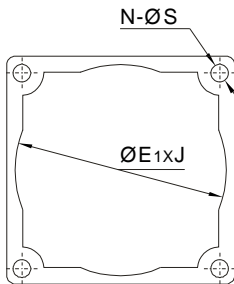

A向
ADIRECTION **T20-T25**

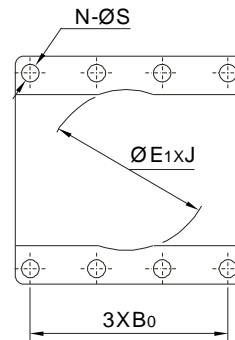

	A ₁	A	A ₀	B	B ₀	C	D ₁	D(h7)	E	E ₁	J	H	L	L ₁	L ₂	L ₄	N	R	S	T
T2	48	100	84	100	84	10	58	15	33	94	3	52	124	82	52	90	4	5	9	17
T4	53.5	155	125	155	125	17	76	19	38	155	5	76	180	117.5	76	116	4	6	10.5	21.5
T6	81	190	152	190	152	17	115	25	50	190	5	90	222	146	87	157	4	8	14	28
T7	88	210	174	210	174	20	125	32	62	220	5	100	265	178	99	175	4	10	14	35
T8	110.5	235	195	235	195	23	159	40	75	250	5	115	308	210.5	114.5	208	4	12	14	43
T10	120	285	240	285	240	25	155	45	90	305	5	140	360	240	133	265	4	14	16	48.5
T12	130	340	290	340	290	32	168	50	100	370	5	175	415	270	160	275	4	14	21	53.5
T16	150	390	330	390	330	40	193	60	105	420	7	200	455	290	186	315	4	18	25	64
T20	195	490	430	410	110	32	220	72	105	360	10	245	545	330	217	360	8	20	21	76.5
T25	235	580	520	480	130	35	270	85	130	430	10	290	660	400	255	430	8	22	24	90